

“Standard caliper”

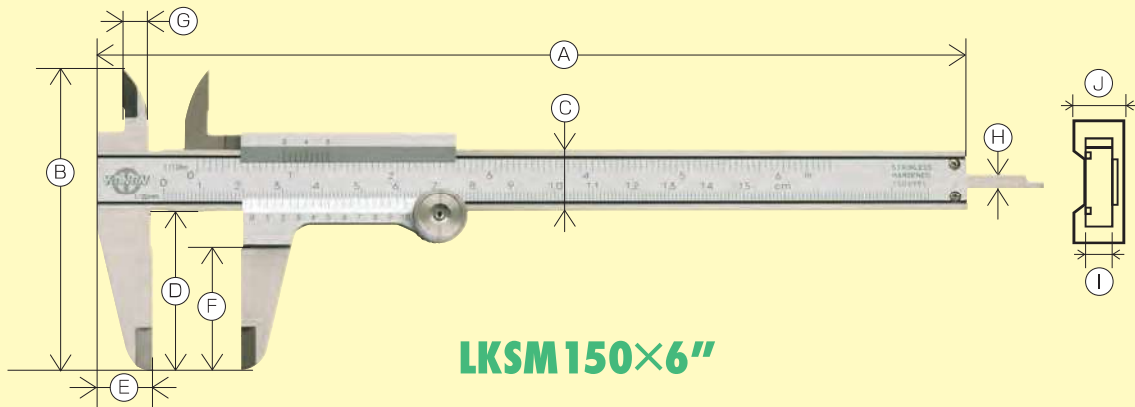

- The upper and lower grooves in the main scale side reduce irregular reflection on the scale surface. In addition, the green color imposes a less load to eyesight, resulting in less fatigue of eyes.

Inside measurement



Outside measurement



Measurement of difference in level

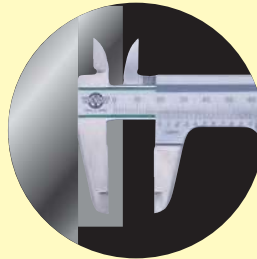

Measurement of depth

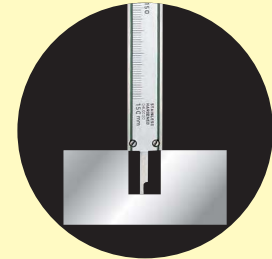

■ LKSM : Specifications

(Unit : mm)

| Model | Measuring length | Minimum reading | Maximum permissible error | | Weight | A | B | C | D | E | F | G | H | I | J |
|-------------|------------------|---|---------------------------|--------|--------|-----|----|----|----|----|----|-----|-----|---|---|
| | | | EMPE | SMPE | | | | | | | | | | | |
| LKSM150×6" | 150mm×6" | 0.05 (Division of 39 mm into 20 equal parts) | ± 0.05 | ± 0.10 | 130g | 230 | 77 | 16 | 40 | 14 | 28 | 7 | 3.8 | 3 | 6 |
| LKSM200×8" | 200mm×8" | | | | 180g | 290 | 91 | 17 | 50 | 17 | 37 | 7.5 | | | |
| LKSM300×12" | 300mm×12" | | | | 250g | 390 | | | | | | | | | |

Mini vernier caliper and standard long scale vernier caliper

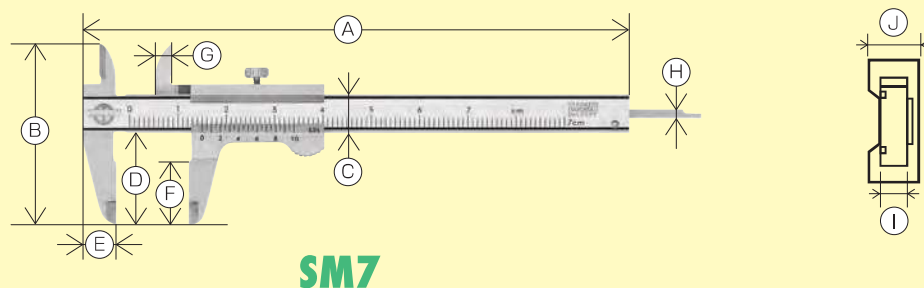

■ SM : Specifications

(Unit : mm)

| Model | Measuring length | Minimum reading | Maximum permissible error | | Weight | A | B | C | D | E | F | G | H × Thickness | I | J |
|-------|------------------|---|---------------------------|--------|--------|------|-------|----|-----|----|-----|-----|---------------|----|-----|
| | | | EMPE | SMPE | | | | | | | | | | | |
| SM7 | 70 | 0.05 | ± 0.05 | ± 0.10 | 23g | 113 | 38 | 8 | 19 | 7 | 13 | 3.5 | 1.8×0.8 | 2 | 4.6 |
| SM150 | 1500 | 0.05 (Division of 39 mm into 20 equal parts) | ± 0.15 | ± 0.20 | 6.5kg | 1780 | 268.7 | 40 | 160 | 45 | 125 | 20 | — | 9 | 16 |
| SM200 | 2000 | | ± 0.20 | ± 0.25 | 12.5kg | 2325 | 330 | 50 | 200 | 50 | 150 | 23 | — | 11 | 20 |
| SM250 | 2500 | | ± 0.25 | ± 0.30 | 14.5kg | 2825 | 330 | 50 | 200 | 50 | 150 | 23 | — | 11 | 20 |
| SM300 | 3000 | | ± 0.30 | ± 0.35 | 17.0kg | 3325 | 330 | 50 | 200 | 50 | 150 | 23 | — | 11 | 20 |
| SM400 | 4000 | | ± 0.40 | ± 0.50 | 25.0kg | 4325 | 330 | 50 | 200 | 50 | 150 | 23 | — | 11 | 20 |

* The minimum reading of SM7 is 0.05 (division of 19 mm into 20 equal parts). * SM150 to SM300 are not equipped with any depth bar.
* SM150-400 is equipped with fine adjustment.