

SBM

Adequate for measurement of step machining part in hole

With "Short leg jaw", this product can be easily used for measurement of step machining part in a hole.

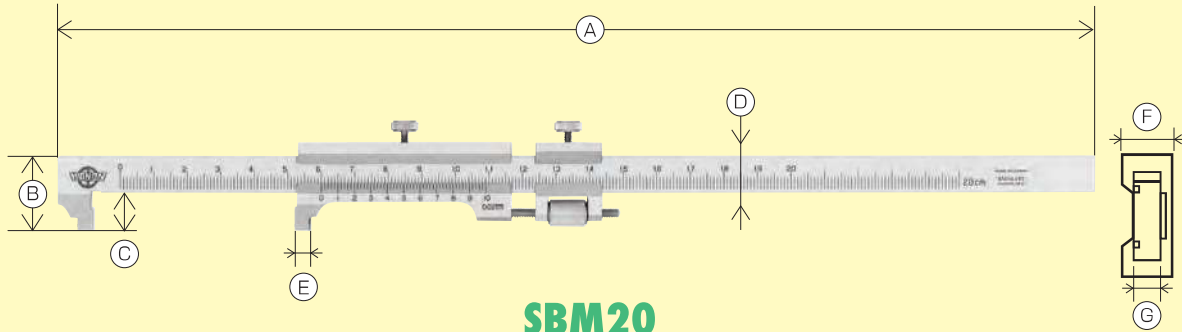

SBM20

- Since the jaw is short, the product is adequate for measurement of step machining in a deep hole.

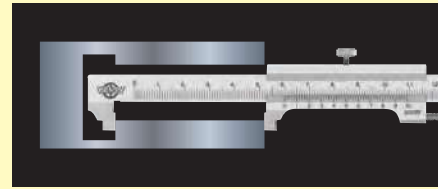

SBM : Specifications

(Unit : mm)

Model	Measuring length	Minimum reading (Division of 49 mm into 50 equal parts)	Maximum permissible error		Weight	A	B	C	D	E	F	G
			EMPE	SMPE								
SBM20	200	0.02	±0.03	±0.05	180g	310	22.5	11.5	11	5	8	4
SBM30	300		±0.04	±0.06	210g	410						

SNAP GAUGE

For inspection of precision of vernier caliper

With "Various sizes", this snap gauge allows quick inspection of inside and outside of vernier caliper.



SNAP GAGE 15



SNAP GAGE STAND

SNAP GAGE : Specifications

(Unit : mm)

Model	Measuring length	Weight
SNAP GAGE5	50	0.4kg
SNAP GAGE10	100	0.5kg
SNAP GAGE15	150	0.6kg
SNAP GAGE20	200	1.0kg
SNAP GAGE30	300	1.6kg

- By mounting the product to the special-purpose stand, the gauge becomes stable, allowing more accurate inspection of vernier caliper.

SNAP GAGE STAND (Options)

Model	Weight
SNAP GAGE STAND(common to all sizes)	3.2kg